

# Fuel injection and air management

Intake manifold and boost-pressure sensor with temperature sensor DS-G3-TF



**BOSCH**

Invented for life

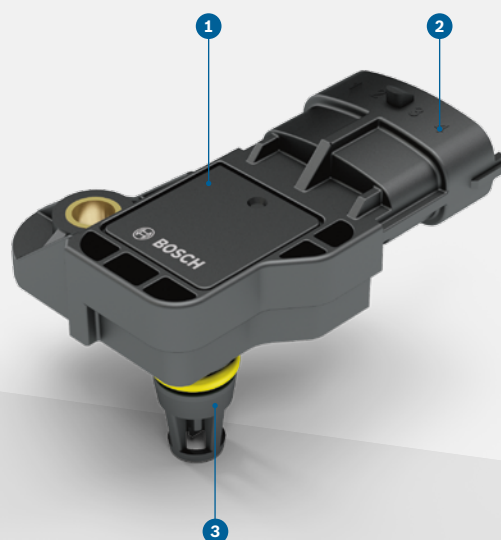

## PRODUCT BENEFITS

- ▶ Precise value for intake manifold pressure and air temperature
- ▶ Precise control of the fuel amount
- ▶ Minimized emissions
- ▶ Excellent media and temperature robustness
- ▶ Developed and certified for natural-gas engines

- 1 Covered electronics compartment
- 2 Cable harness connector
- 3 Pressure socket and temperature sensor



# minimal emissions

due to optimum air-fuel mixture

## TASK

The intake manifold and boost-pressure sensor with integrated temperature sensor enables a fast and precise measurement of intake air pressure and temperature, at natural aspirated and turbocharged internal combustion engines. The sensor so supports the precise control of fuel amount and minimized emissions.

## FUNCTION

The sensor measures pressure by using a resistance bridge to evaluate the distortion of a silicon membrane. A gel covering the membrane protects the sensor against deposits. Temperature is measured with an NTC (negative temperature coefficient) resistor. The signals for pressure and temperature are transmitted to the control unit over two lines.

## VARIANTS

The sensor is available in various housings and for different pressure ranges.

# optimum performance

due to precise control of fuel amount

## TECHNICAL CHARACTERISTICS

|                            |                       |
|----------------------------|-----------------------|
| Temperature range          | -40 °C to +120 °C     |
| Pressure measurement range | 20..50 – 350..450 kPa |
| Max. operating pressure    | 500 kPa               |
| Operating voltage          | 5V                    |

- 1 Electronics compartment
- 2 O ring
- 3 NTC (optional)
- 4 Cable harness connector

